

Built-in Dual Fan Oven

NV66H3523LS/EE



Dual Fan

All Samsung convection ovens use double convection fans. We take this standard for granted as it gives our ovens a faster and more even heating.



A - Energy Efficiency

Tasty food does not have to cost the earth. This Samsung oven has an A graded Energy Efficiency which saves



Capacity – 65L

Cater for even the largest family or group of friends. With a huge 65 liter capacity you can easily roast a big 10 kilo turkey, ensuring that it is thoroughly cooked and full of flavor.



Child Lock

Enjoy complete peace of mind and keep little hands away from danger. Samsung ovens are childproof with special safety locks to prevent them being opened accidentally.



Catalytic Cleaning

Imagine an oven that cleans itself while it's working. With Catalytic cleaning the food remnant tray collects grease and residue and chemically dissolves them, so your oven is always clean.



Samsung

NV66H3523LS/EE

EAN: 8806086160568

Built-in Dual Fan Oven



NV66H3523LS/EE

Cook any dish anywhere in the oven and get perfect results every time. Airvection technology uses two fans to spread heat evenly throughout the oven and deep inside the food.

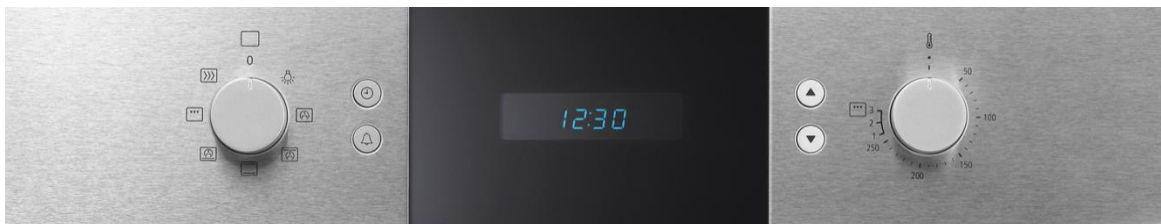

Oven Features	EAN	8806086160568
	Oven type	Dual Fan
	Cavity Interior	Ceramic Enamel
	Oven Doors	3xglass
	Display Color	Blue
	Door Opening Type	Drop Down
	Interior Lamp	1 x25W
	Control Method	Pop-up Dial / Buttons
	Cleaning Method	Catalytic
	Steam Cleaning	-
	Electronic Features	Auto Menu
Oven Temp. Ranges , Single		50 ~ 250 °C (Grill 1/2/3)
Oven Temp. Ranges , Upper / Lower		-
Oven Temp. Ranges , Twin		-
Upper Grill, In / Out		1,600W/700W
Lower Grill		600W
Convection, Upper / Lower		1700W
Energy Class (Convection)		A
Control Features	Energy Consumption (Conventional)	0.89kwh
	Clock	Yes
	Child Lock (electronic)	Yes
	Mechanical Lock	Yes
	Timer	-
	End Time	-
	Light (Lamp) On / Off	-
Accessories	Square Baking Tray	2
	Wire Shelf	2
	12L Steamer	-
	Telescopic Rack	-
	Cook Book	-
Measurements	Usable Cavity	66L
	Outside dimensions, W x H x D (mm)	595 x 595 x 566
	Cutout dimensions, W x H x D (mm)	560 x 572 x 545
	Packing dimensions, W x H x D (mm)	682X656X645
	Net weight (kg)	35,0
	Gross weight (kg)	37,0

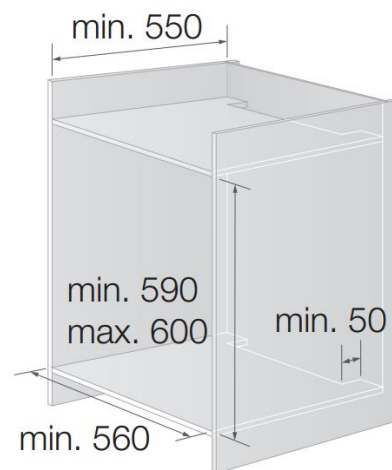
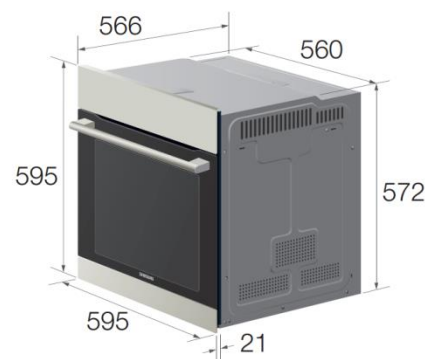

Samsung

NV66H3523LS/EE

EAN: 8806086160568

Support 0771-SAMSUNG (0771-7267864)

www.samsung.se

The information in this document is subject to change without notice